



Main characteristics

- Absolute transducer
- Strokes from 50 to 4000mm (RK-2-____-N/E/S)
- Digital output RS422 Start/Stop (RK-2-____-S)
- Direct analog output (RK-2-____-N/K/E)
- Operating temperature: -30...+90°C
- Resistance to vibration (DIN IEC68T2/6 20g)
- Power supply 18Vdc...30Vdc
- Optional 12Vdc power supply (RK-2-____-K)
- The digital version (RK-2-____-S) allows the remote connection (max. 50 m) of optional electronics for use of advanced analog (EKA)

Contactless linear position transducer with magnetostrictive technology: the absence of electrical contact on the cursor eliminates problems of wear and consumption and guarantees almost unlimited life.

The head's flanged shape and small size make the RK-2 series ideal for applications requiring installation completely inside the hydraulic cylinder.

The overall dimensions of the sensor are among the smallest available on the market.

For the interface signal, you can choose between a start/stop interface (which allows the use of multiple cursors) and an analog interface that gives the displacement of a single cursor (available in the several ranges in Voltage or Current).

Excellent linearity, repeatability, resistance to mechanical vibrations and shocks complete the product's specifications overview.

TECHNICAL DATA

Model

from 50 to 4000 mm (max. 1200 mm RK-2-____-K)

Measurement taken

Displacement

Position read sampling time (typical)

1 ms

Shock test DIN IEC68T2-27

100g - 11ms - single shock

Vibrations DIN IEC68T2-6

20g / 10...2000Hz

Displacement speed

≤ 10 m/s

Max. acceleration

≤ 100 m/s² displacement

Resolution

Infinite, limited by noise (10µm)

Working pressure

350 bar (peak max 500 bar)

Nominal power supply

18...30Vdc opz. 12Vdc (RK-2-____-K)

Max. power ripple

1Vpp

Output signal

Start/Stop (RK-2-____-S)
0,1...10,1Vdc (RK-2-____-N)
0,1...5,1Vdc (RK-2-____-K)
4...20mA (RK-2-____-E)

Max. analog output load

5KΩ

Output current consumption

max 40 mA (load on start/stop output:300 Ω)

Electric isolation

100 Vdc

Protection against polarity inversion

YES

Protection against overvoltage

YES

Protection in hydraulic circuit area

IP67

Operating temperature

-30...+90°C for strokes ≤ 2500mm and power supply ≤ 24 Vcc
otherwise -30...+70°C

Storage temperature

-40...+100°C

Coefficient temperature

0.005% FS / °C

MECHANICAL DIMENSIONS

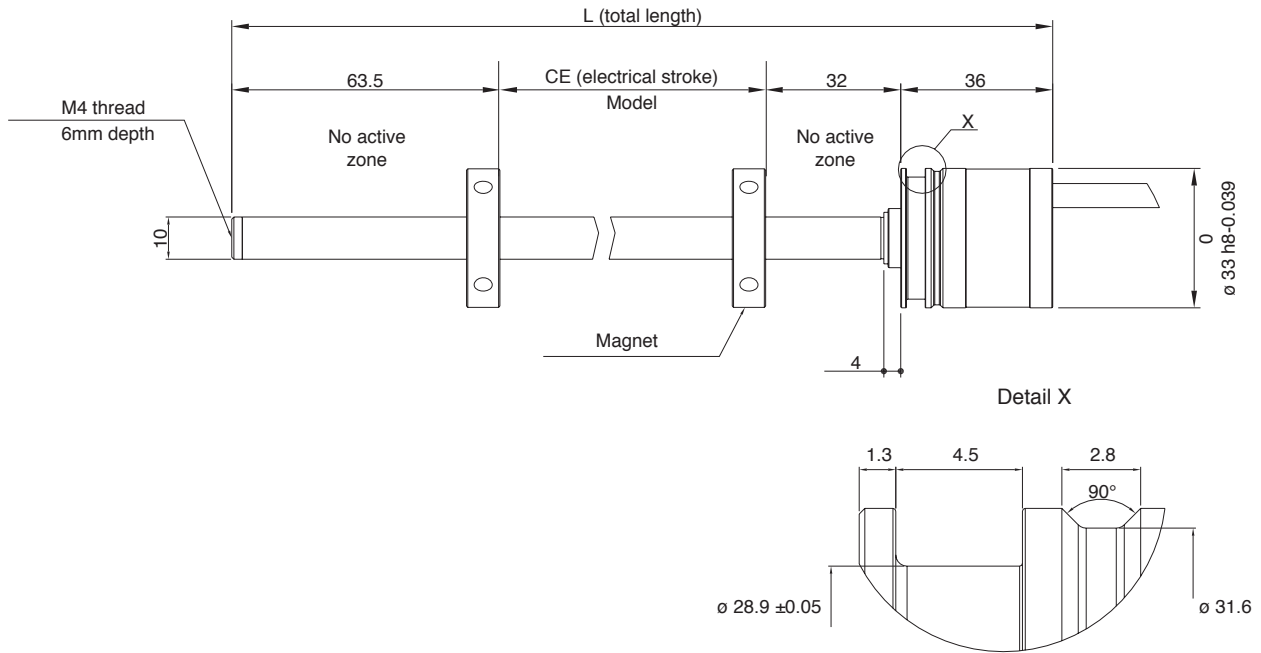

MOUNTING INSIDE A CYLINDER

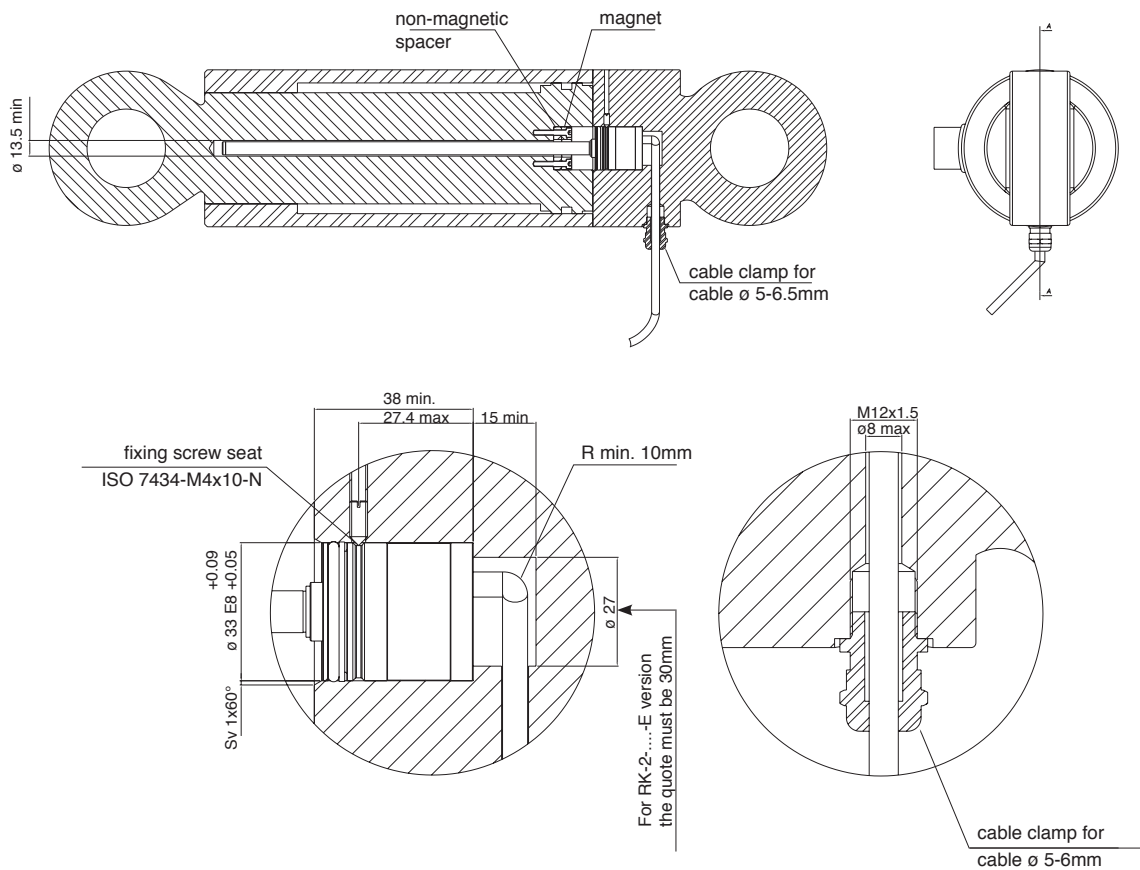

ELECTRICAL / MECHANICAL DATA

Model	mm	50	100	130	150	200	225	300	400	450	500	600	700	750	800	900	1000
							1250	1500	1750	2000	2250	2500	2750	3000	3250	3500	3750
Electrical stroke (C.E.)	mm	Model															
Independent linearity		$< \pm 0.02\% \text{ F.S. (Min. } \pm 0.060 \text{ mm)}$															
Max. dimensions (L)	mm	Model + 131.5 (excluding cable)															
Repeatability	mm	< 0.01															
Hysteresis		$< \pm 0.005\% \text{ F.S.}$															
Sampling time	msec	1 (1.5 for strokes from 1100 to 2000) (2 for strokes from ≥ 2000)															

ELECTRICAL CONNECTIONS (RK- 2 - _ _ _ _ - S)

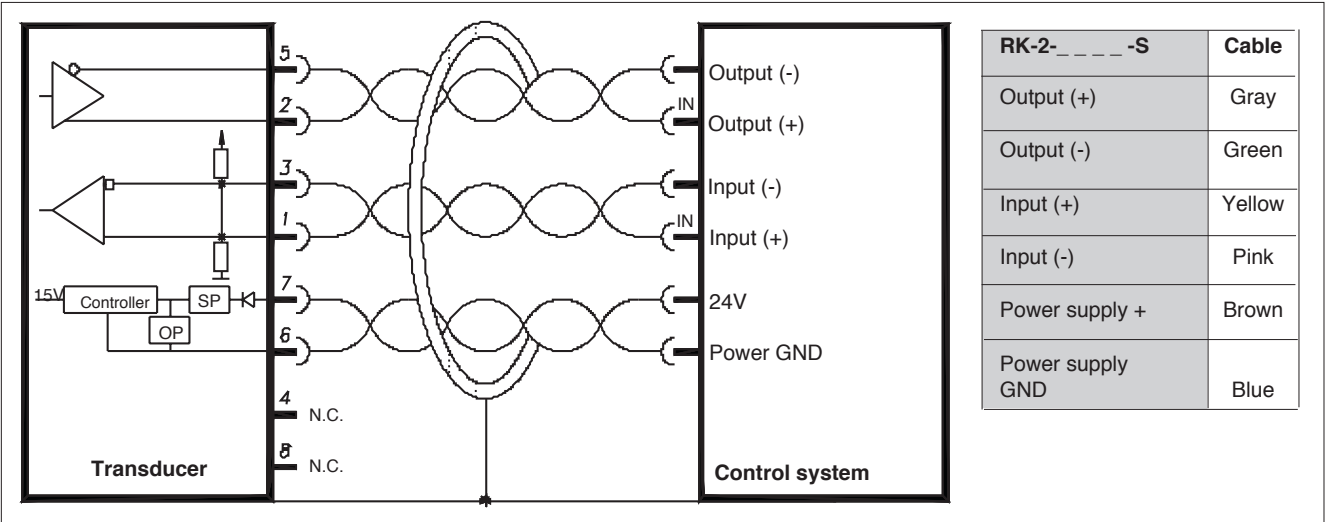

ELECTRICAL CONNECTIONS (RK- 2 - _ _ _ _ - N/K/E)

RK-2- _ _ _ _ -N	RK-2- _ _ _ _ -K	RK-2- _ _ _ _ -E	Cable
Output 0.1...10.1Vdc	Output 0.1...5.1Vdc	Output 4...20mA	Yellow
Output GND	Output GND	Output GND	Pink
Power supply +	Power supply +	Power supply +	Brown
Power supply GND	Power supply GND	Power supply GND	Blue

IMPORTANT: in case of cable length shortening, after cutting the cable take care of soldering and insulating the green and grey wires together

DIGITAL OUTPUT RK- 2 - _ _ _ _ - S

Series RK-2- _ _ _ _ -S magnetostrictive transducers supply digital outputs in START/STOP format with RS422 differential serial transmission.

The transducer requests an Initialisation pulse that launches sampling. The following pulses are transmitted on the outputs:

Start: the Initialisation pulse retransmitted

Stop: the pulse corresponding to the position of each magnet.

The time between the Start pulse and the subsequent Stop pulses is proportional to the position of each magnet according to the "Magnetostrictive wave propagation speed" constant, equal to about 2900 m/Ssec.

$$\text{Time} * 2900\text{m/Sec}$$

The correct propagation speed for each product is shown on the product label.

Resolution in terms of metres is linked to the resolution used to measure time

- 1 μSec (1MHz) $\Rightarrow 2.9 \text{ mm}$
- 10 nSec (100 MHz) $\Rightarrow 0.029\text{mm}$
- 1 nSec (1GHz) $\Rightarrow 2.9 \mu\text{m}$

The measurement reference is the leading edge of the pulse.

Optimum width of the interrogation pulse is $3\mu\text{Sec}$, but the transducer works correctly for times from 1.5 to $5\mu\text{Sec}$

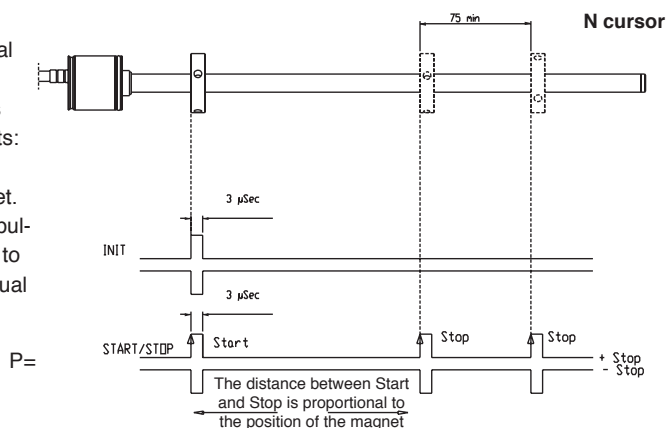

ORDER CODE

Position transducer

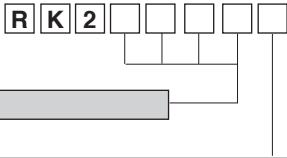

Model

Output

Start/Stop	Start/Stop interface	S
Analog	0.1...10.1Vdc interface (power supply 18...30Vdc)	N
Analog	0.1...5.1Vdc interface (power supply 12Vdc)	K
Analog	4...20mA interface (power supply 18...30Vdc)	E

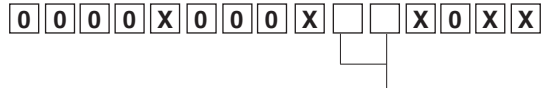

Connection cable to remote element (PUR)

00 = 1 mt 02 = 2 mt 03 = 3 mt
04 = 4 mt 05 = 5 mt 10 = 10 mt
15 = 15 mt

Mechanical and/or electrical characteristics differing from those in the standard version may be arranged on request.

FLOATING CURSOR (to order separately)



Cursors

Cursor diameter 32.8	022
Cursor diameter 32.8 with 90° slit	023
Cursor diameter 25.4	024

Dimensions	A	B	C	Thickness
PCUR022	32.8	13.5	23.9	7.9
PCUR023				
PCUR024	25.4	13.5	-	

PCUR022

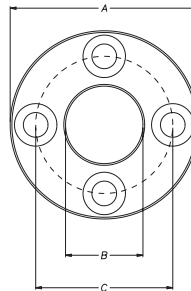

The **PCUR022** is supplied with:

N° 8 Brass nuts M4
N° 8 Brass washers D4
N° 4 Brass screws M4x25

PCUR023

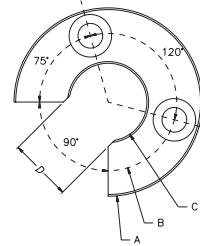

The **PCUR023** is supplied with:

N° 4 Brass nuts M4
N° 4 Brass washers D4
N° 2 Brass screws M4x25

PCUR024

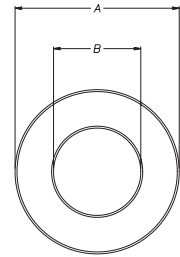

OPTIONAL ACCESSORIES (to order separately)

Cable clamp

PRE060

OPTIONAL REMOTE ELECTRONICS FOR RK-2-____-S



Available in two versions

- With analog voltage or current output for displacement and speed measurement (model EKA)

Main features

- Option for zero and full-scale adjustment over 100% of the stroke via “magnetic pen” (available on model EKA)
- Power range 10...30Vdc
- Connection to remote electronics via connector or screw terminal (PUR cable, \varnothing 5 mm)
- MAX distance of remote electronics from sensor: 50 m

TECHNICAL DATA (EKA)

Measurement taken	Displacement / Speed	
Speed range	0.1 ... 10 m/s	
Accuracy speed	< 2 % (in all F.S.)	
Speed calculation time	Sampling time + 500 μ sec	
Resolution	16 bit	
Output signal	0...10V (N,P) 0...5V (K)	4...20mA (E,F) 0...20mA (B,C)
Nominal power supply	10...30Vdc	10...30Vdc
Max. power ripple	1Vpp	1Vpp
Current consumption	Depends on power supply voltage: max 70mA with power supply of 30Vdc * max 85mA with power supply of 24Vdc * max 110mA with power supply of 18Vdc ** max 200mA with power supply of 10Vdc ** * peak 0,2A at power ** peak 0,4A at power	
Output load	2 K Ω	< 500 Ω
Max. output ripple	< 5 mV pp	< 5 mV pp
Max. output value	10.6 V	25 mA
Electrical isolation	200 V	200 V
Protection against polarity inversion	YES	YES
Protection against overvoltage	YES	YES
Self-resetting internal fuse	YES	YES

MECHANICAL DIMENSIONS

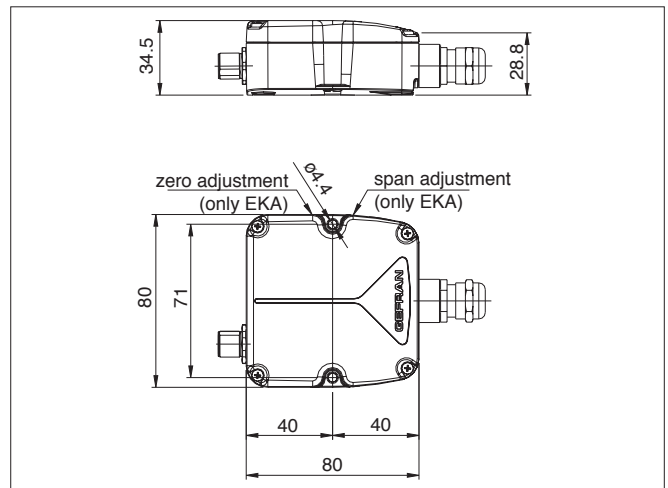

ELECTRICAL CONNECTIONS

RK- - - - -S-EKA- -M- - -

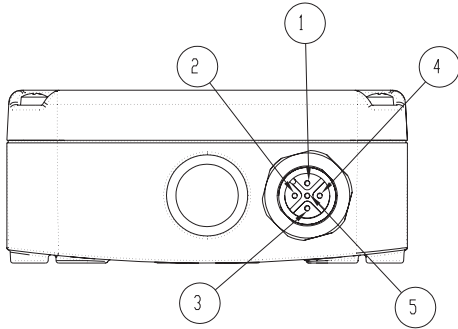

RK- - - - -S-EKA- -B- - -

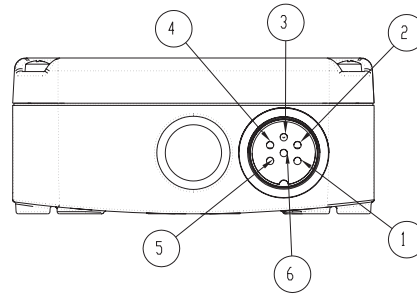

Function	EKA- -M- - - M12 5-pin	EKA- -B- - - M16 6-pin DIN 45322	Optional cable for M12
Output 1 (displacement) 0...10V 0...5V 4...20mA 0...20mA	1	1	Brown
GND shift 1 (0V)	2	2	White
Output 2 reverse displacement, or speed depending on the model 0...10V 0...5V 4...20mA 0...20mA	3	3	Blue
GND shift 1/2 (0V)	2	4	White
Power supply +	5	5	Grey
Power supply -	4	6	Black

INTERCONNECTION BETWEEN PRIMARY SENSOR AND REMOTE ELECTRONICS

RK- - - - -S-EKA - - - - R - -

(interconnection with wire clamp and screw terminals)

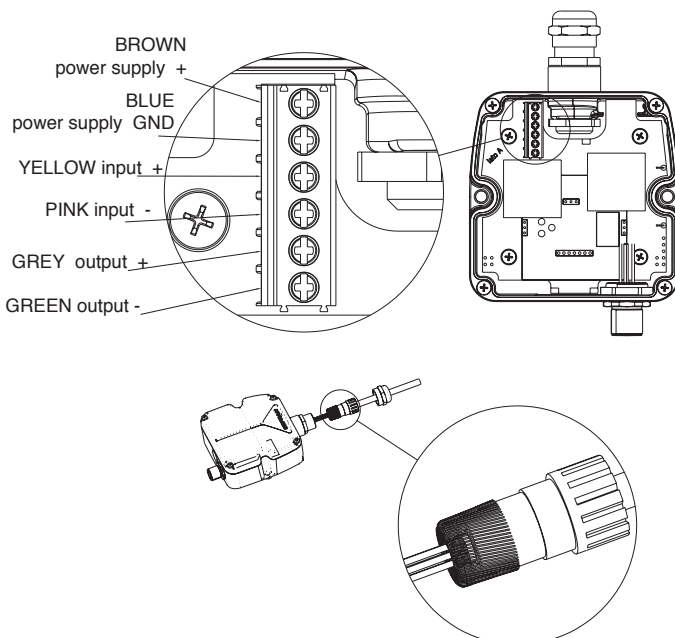

RK- - - - -S-EKA - - - - M - -

(interconnection with M12 8-pin connector)

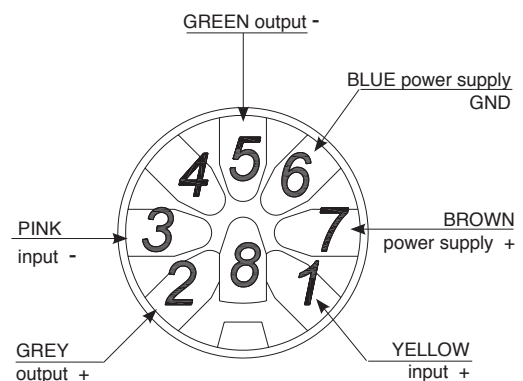

Attention:
do all wiring BEFORE powering the electronics
(i.e., with unit off).

CALIBRATION WITH MAGNETIC PEN (option RK- _ - _ _ _ -S-EKA-D- _ - _ - _)

The magnetic pen is needed to calibrate the useful stroke of the transducer in a manner other than as configured in the factory (default).

• CALIBRATION OF ZERO POINT

when the magnet is at the required zero point, position the magnetic pen in the ZERO zone for a time between 0.5 and 10 seconds.

• CALIBRATION OF FULL-SCALE POINT

when the magnet is at the required full-scale point, position the magnetic pen in the FS zone for a time between 0.5 and 10 seconds.

• SAVING THE NEW CALIBRATION

position the magnetic pen in the ZERO or FS zone for a time between 10 and 60 seconds. The programmed configuration will be saved and active at the next power-up.

• RESTORING FACTORY DEFAULT CALIBRATION

position the magnetic pen in the ZERO or FS zone for more than 60 seconds. This will restore the original factory calibration in the internal EEPROM.

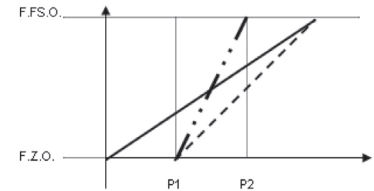

— Factory

- - - Zero button with Magnet in P1

- . . FS button with magnet in P2

F.Z.O: 0V, 4mA, 0mA, -10V, -5V

F.F.S.O: 10V, 20mA, 0mA, +10V, +5V

ORDER CODE (RK-2 with EKA analog remote electronics)

Position transducer **R** **K** **2** **S** - **E** **K** **A**

0 **0** **0** **0** **X** **X** **0** **X** **X**

Model

Analog output	A
Analog output with zero and span setting	D

Output connector type

M12, 5-pin connector output	M
DIN 45322 6-pin connector output	B

Type of connection to the primary sensor

Internal screw terminal	R
M12, 8-pin connector	M

Output

0...10Vdc	1 Cursor, double output position (standard)	N
0...10Vdc	1 Cursor, position and speed	P
4...20mA	1 Cursor, double output position	E
4...20mA	1 Cursor, position and speed	F

Available on request

0...20mA	1 Cursor, double output position	B
0...20mA	1 Cursor, position and speed	C
0...+5Vdc	1 Cursor, double output position	K(*)

(*) The maximum stroke for the K version is 1200mm

Output of speed

Only for analogic output option C, F, P	
Max. measurable speed: 0.1 ÷ 10.0 m/s	
00.0	Function not required

Power supply

S	10...30V (standard)
----------	---------------------

Connection cable to remote element

00	= 1 mt	02	= 2 mt	03	= 3 mt
04	= 4 mt	05	= 5 mt	10	= 10 mt
15	= 15 mt				

Mechanical and/or electrical characteristics differing from those in the standard version may be arranged on request.

OPTIONAL CONNECTORS FOR EKA OUTPUT

(to order separately)

For M outputs, M12 thread connector
(for RK-_-_-_-S-EKA-_-M-_-_-)

Code: **CON031** 5-pin
CON041 5-pin

For B outputs, M16 thread connector
(for RK-_-_-_-S-EKA-_-B-_-_-)

Code: **CON021** 6-pin
CON022 6-pin
CON023 6-pin

Connector extraction length: 10mm

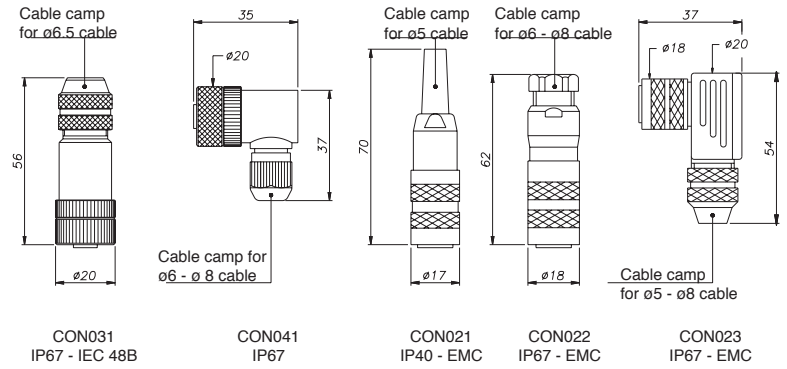

OPTIONAL CABLES FOR EKA OUTPUT

(to order separately)

Cable Code (for RK-_-_-_-S-EKA-_-M-_-_-)			
Length "L"		CODE	
		Straight cable	Cable to 90°
2	mt	CAV011	CAV021
5	mt	CAV012	CAV022
10	mt	CAV013	CAV023
15	mt	CAV015	CAV024

OTHER ACCESSORIES FOR USE WITH EKA

(to order separately)

M12, 8-pin axial male connector for interconnection	CON460
Magnetic pen to calibrate remote electronic (model EK-A-D)	PKIT312

Sensors are manufactured in compliance with:
- EMC 2014/30/EU compatibility directive
- RoHS 2011/65/EU directive

GEFRAN spa reserves the right to make any kind of design or functional modification at any moment without prior notice.